



Il metodo scientifico

The scientific method

La méthode scientifique





Quando il metodo scientifico diventa ispirazione...

When the scientific method becomes inspiration...

Quand la méthode scientifiques devient inspiration...





- Abbiamo voluto riprodurre un movimento naturale per l'uomo, ma non per due pinze meccaniche. Quindi abbiamo elaborato un algoritmo per dar vita al Vitap DDT® System.
- We wanted to reproduce a natural movement for humans, but not for two mechanical grippers. So we developed an algorithm to give life to the Vitap DDT® System.
- Nous voulions reproduire un mouvement naturel pour l'homme, mais pas pour deux pinces mécaniques. Nous avons donc développé un algorithme pour donner vie au Système DDT® de Vitap.



Click to see the VIDEO

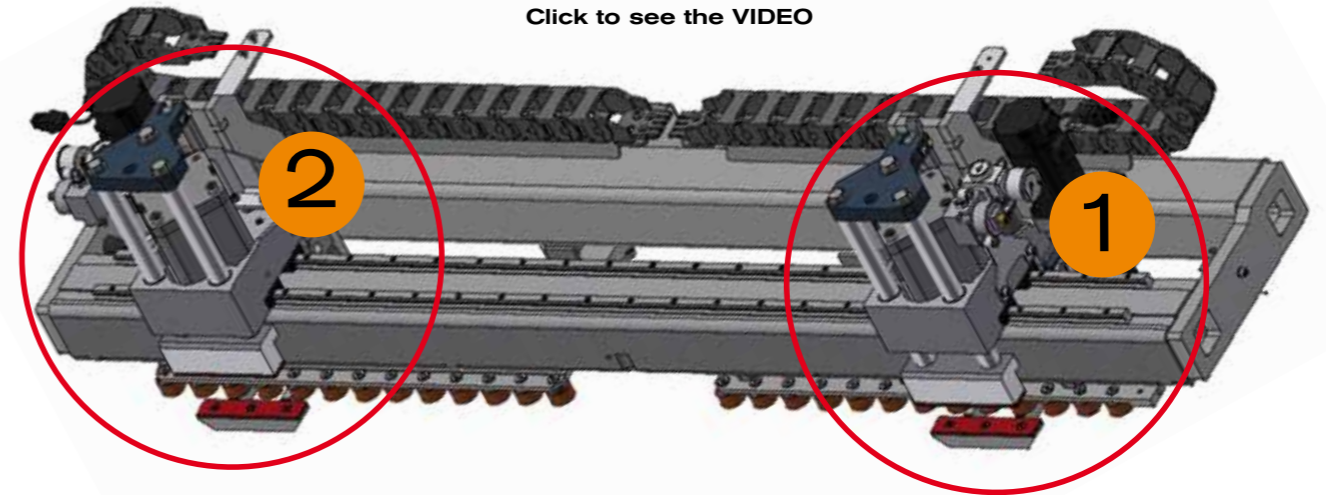

- Macchina equipaggiata con brevetto rivoluzionario **D-D-T®** (Double Dynamic Transport) realizzato con n.2 pinze robuste per la translazione del pannello senza soluzione di continuità, con scorrimento su guida lineare a movimentazione con vite a ricircolo di sfere di alta precisione e rigidezza. Motorizzazione BRUSHLESS.
- Machine equipped with revolutionary patented **D-D-T®** (Double Dynamic Transport) made with n.2 sturdy clamps for seamless translation of the panel, with preloaded ball bearings and moving by means of ballscrew with high precision and stiffness BRUSHLESS motor.
- Machine équipée avec brevet révolutionnaire **D-D-T®** (Double Dynamic Transport) fabriqué avec n.2 pinces robustes à mouvement continu sur les guides linéaires et mouvement par vis à recirculation de sphères précis et rigides. Motorisation BRUSHLESS.

video 1

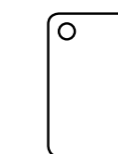

scan the QR



OR



touch the QR



Tecnologia Technology Technologie

- Massima cura per la qualità del mobile finito: ogni singolo pannello durante la lavorazione appoggia sempre sulla parte corrispondente al lato interno del mobile, assicurando l'assenza di imperfezioni sulla parte esterna.
- Excellent quality of final product: each panel is machined laying on furniture's inner side, preventing the outer side from any scratch.
- Qualité excellente du meuble fini: durant l'usinage, chaque panneau est en appui sur la partie interne du meuble garantissant ainsi l'absence d'imperfection sur la partie externe.



video 2

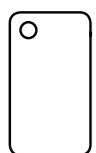

scan the QR



OR



touch the QR



Layout gruppo operatore • Layout operating units • Layout groupe operateur

Galileo 1

N.9 mandrini indipendenti verticali
N. (2+2) mandrini orizzontali asse X
N. (2+2) mandrini orizzontali asse Y

N.9 independent vertical spindles
N. (2 + 2) X axis horizontal spindles
N. (2 + 2) Y axis horizontal spindles

N.9 broches verticales indépendantes
N. (2 + 2) broches horizontales axe X
N. (2 + 2) broches horizontales axe Y

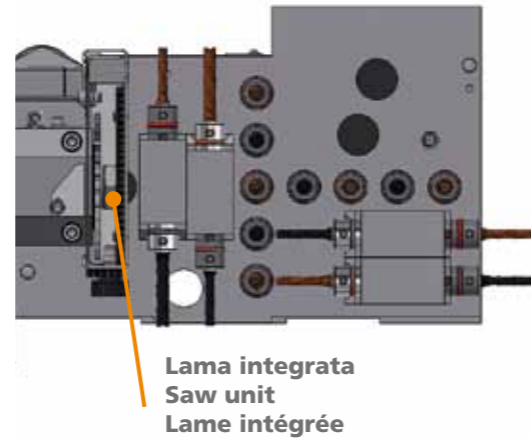

Lama integrata
Saw unit
Lame intégrée

Galileo 2

N.9 mandrini indipendenti verticali
N. (2+2) mandrini orizzontali asse X
N. (2+2) mandrini orizzontali asse Y

N.9 independent vertical spindles
N. (2 + 2) X axis horizontal spindles
N. (2 + 2) Y axis horizontal spindles

N.9 broches verticales indépendantes
N. (2 + 2) broches horizontales axe X
N. (2 + 2) broches horizontales axe Y

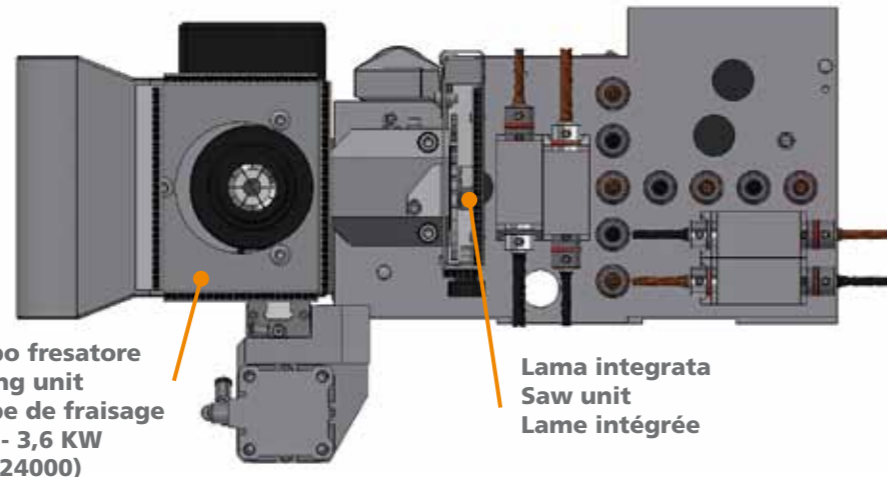

Gruppo fresatore
Routing unit
Groupe de fraisage
ER 32 - 3,6 KW
(Rpm 24000)

Lama integrata
Saw unit
Lame intégrée

Galileo 3

N.9 mandrini indipendenti verticali
N. (2+2) mandrini orizzontali asse X
N. (2+2) mandrini orizzontali asse Y

N.9 independent vertical spindles
N. (2 + 2) X axis horizontal spindles
N. (2 + 2) Y axis horizontal spindles

N.9 broches verticales indépendantes
N. (2 + 2) broches horizontales axe X
N. (2 + 2) broches horizontales axe Y

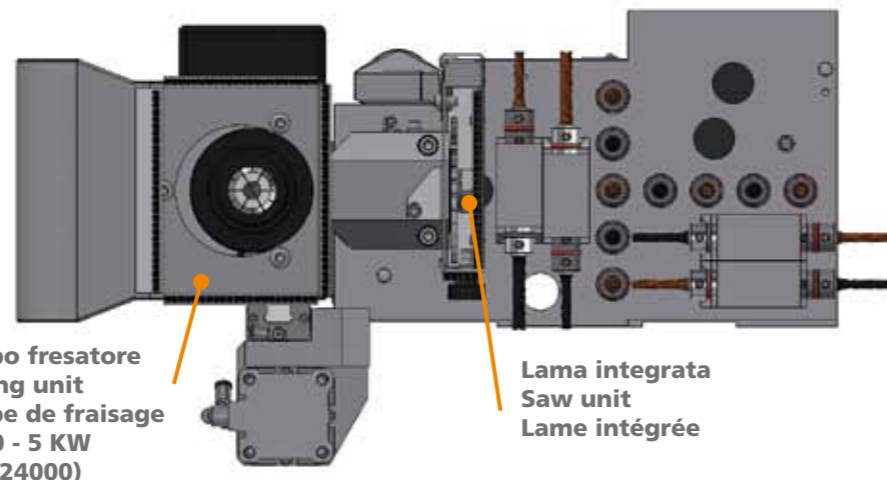

Gruppo fresatore
Routing unit
Groupe de fraisage
ISO 30 - 5 KW
(Rpm 24000)

Lama integrata
Saw unit
Lame intégrée

Standard configuration for: Galileo 1 • Galileo 2 • Galileo 3

Nessun limite di lunghezza pannello ∞ • No limit on panel length ∞ • Aucune limite sur la longueur du panneau ∞
 Fresatura dal basso e ritorno automatico del pezzo all'operatore + selettore automatico per l'uscita del pannello sul retro della macchina
 • Bottom milling and automatic return of the piece to the operator + automatic selector for the exit of the panel on the back of the machine
 • Fraisage par le bas et retour automatique de la pièce à l'opérateur + sélecteur automatique pour la sortie du panneau à l'arrière de la machine
 Elevata produttività e flessibilità • High productivity and flexibility • Productivité et flexibilité élevées
 4 assi controllati • 4 controlled axes • 4 axes contrôlés
 Asse X motore Brushless di ultima generazione con ingranaggio riduttore epicicloidale, pignone e cremagliera di alta precisione • Latest generation Brushless X axis motor with planetary reduction gear, pinion and high precision rack • Axe X, moteur Brushless de dernière génération avec réducteur planétaire, pignon et crémaillère de haute précision
 Asse Y motore Brushless di ultima generazione con ingranaggio riduttore epicicloidale, pignone e cremagliera di alta precisione • Latest generation brushless Y axis motor with planetary reduction gear, pinion and high precision rack • Axe Y, moteur Brushless de dernière génération avec réducteur planétaire, pignon et crémaillère de haute précision
 Asse Z motore brushless di ultima generazione e foratura pannello e movimento a vite con ricalcolo di sfere • Z axis latest generation brushless motor and panel drilling and screw movement with recalculation of spheres • Axe Z, moteur Brushless de dernière génération avec réducteur planétaire, pignon et crémaillère de haute précision
 PC industriale per alte prestazioni di programmazione • Industrial PC for high programming performance • PC industriel pour des performances de programmation élevées
 Programmazione semplice • Simple programming • Programmation simple
 Monitor LCD TFT 20" • 20" TFT LCD monitor • Moniteur LCD TFT 20"
 Porta USB per caricare programmi eseguiti su una stazione cad in ufficio • USB port for uploading programs run on a cad station in the office • Port USB pour télécharger des programmes exécutés sur une station CAD au bureau
 Software per l'ottimizzazione del taglio • Cut optimization software • Logiciel d'optimisation de coupe
 CAD per la programmazione grafica TPA • CAD for TPA graphic programming • CAD pour la programmation graphique TPA
 CAD nella versione base • CAD in the basic version • CAD dans la version de base
 Memorizzare tutti i file con tutti i dati • Store all files with all data • Stockez tous les fichiers avec toutes les données
 Programmazione macro • Macro programming • Programmation macro
 Importazione file DXF controllo digitale completo parametrico • DXF file import complete parametric digital control • Importation de fichiers DXF Contrôle numérique paramétrique complet

Dimensioni Max pannello • Max panel dimensions • Dimensions maximales du panneau:	X ∞, Y 920 mm, Z 50 mm
Dimensioni min.pannello • Min panel dimensions • Dimensions minimales du panneau:	X 270/400 *, Y 185 (70 opt.) , Z 3 mm (* 270 mm con limiti)
Max peso pannello • Max panel weight • Poids maximum du panneau:	kg 50
Rotazione mandrini • Spindle rotation • Rotation de la broche	3600 RPM
Rotazione sega circolare • Circular saw rotation • Rotation de la scie circulaire	7000 RPM
Avanzamento pannello Asse X • Panel feed X Axis • Avancement panneau axe X	25 m/min
Profondità max di foratura in vert. • Max vertical drilling depth • Profondeur Max de perçage vertical	43 mm
Diametro Max punta verticale • Max vertical tip diameter • Diamètre maximal de la mèche verticale	35 mm
Motore • Engine • Moteur	1,7 KW
Diametro Max punta orizz. • Max horizontal tip diameter • Diamètre maximal de la mèche horizontale	12 mm
Dimensioni • Dimensions • Dimensions	2900 x 1650 x 1890 mm
Peso • Weight • Poids	1310 kg
Norme CE	

video 1

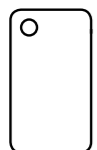

scan the QR



OR



touch the QR

video 2

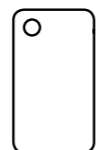

scan the QR



OR



touch the QR

Le descrizioni tecniche contenute in questo documento sono inserite a puro scopo indicativo-illustrativo, pertanto non hanno alcun valore contrattuale. Vitap si riserva il diritto di effettuare cambiamenti e/o migliorie sui prodotti illustrati nel proprio listino prezzi senza obbligo di preavviso. Le misurazioni, i pesi, i colori, le dimensioni ivi indicate possono, pertanto, subire delle variazioni. I prezzi da listino sono da considerarsi come "prezzi consigliati al pubblico", a cui ciascun cliente dovrà poi applicare la scontistica al medesimo riservata. Le immagini e disegni in questo documento hanno solo scopo illustrativo, pertanto non hanno alcun valore contrattuale.

